



Features

1. 300A ;
2. ;
3. 24W;
Coil power consumption \hat{O} 24W.
4. 100M (1000VDC) 3.5kV;
The insulation resistance reaches 100M (1000VDC), and the withstand voltage between the contacts and the coil is 3.5kV.
5. IP :IP67;
6. IEC 60664-1 GB/T14048.1 GB/T14048.4 ;
Compliant with IEC 60664-1, GB/T14048.1 and GB/T14048.4 requirements.
7. RoHS 2015/863/EU REACH 1907/2006/EC ;
Compliant with RoHS (2015/863/EC) and REACH (1907/2006/EC) requirements.
8. CE;

at23

Performance Parameters at23

	2K (2NO), 2B (2NC)	Pickup Voltage	70% U _s
	30m	Dropout Voltage	5% -40% U _s
Contact Voltage Drop	80mV(at 80A)	Contact Bounce Period	5ms
	4le, 1s		30ms
	-40 ~85	Dropout Time	30ms
	M6	Dielectric Strength	Between Main Contacts 50Hz/60Hz 1500VAC/1min
Vibration	3.5g,10~200Hz,1/2 3.5g,10~200Hz,1/2 Sine Wave (Power On)		Between Main Contacts and Coil 50Hz/60Hz 1500VAC/1min
	5 ~95 RH		100M 1min
Dimension	86mm*51mm*78mm		50M 1min
Operating Duty			20g 20g (Power On)
Electrical Durability with Load (Resistive)	20000 \hat{O} 20,000 Times		50g
Load Wiring Torque	3-6N.m	Mechanical Durability	100000 \hat{O} 100,000 Times
/	/	Coil Wiring Torque	0.5-0.8N.m

ADC300IJ

ADC300IJ Coil Parameters

Coil Voltage	Pickup Voltage	Dropout Voltage		
12V	70% U _s	5% -40% U _s	6 ± 10%	24W± 10%
24V	70% U _s	5% -40% U _s	24 ± 10%	24W± 10%
36V	70% U _s	5% -40% U _s	54 ± 10%	24W± 10%
48V	70% U _s	5% -40% U _s	96 ± 10%	24W± 10%
60V	70% U _s	5% -40% U _s	150 ± 10%	24W± 10%
72V	70% U _s	5% -40% U _s	216 ± 10%	24W± 10%

Model Coding

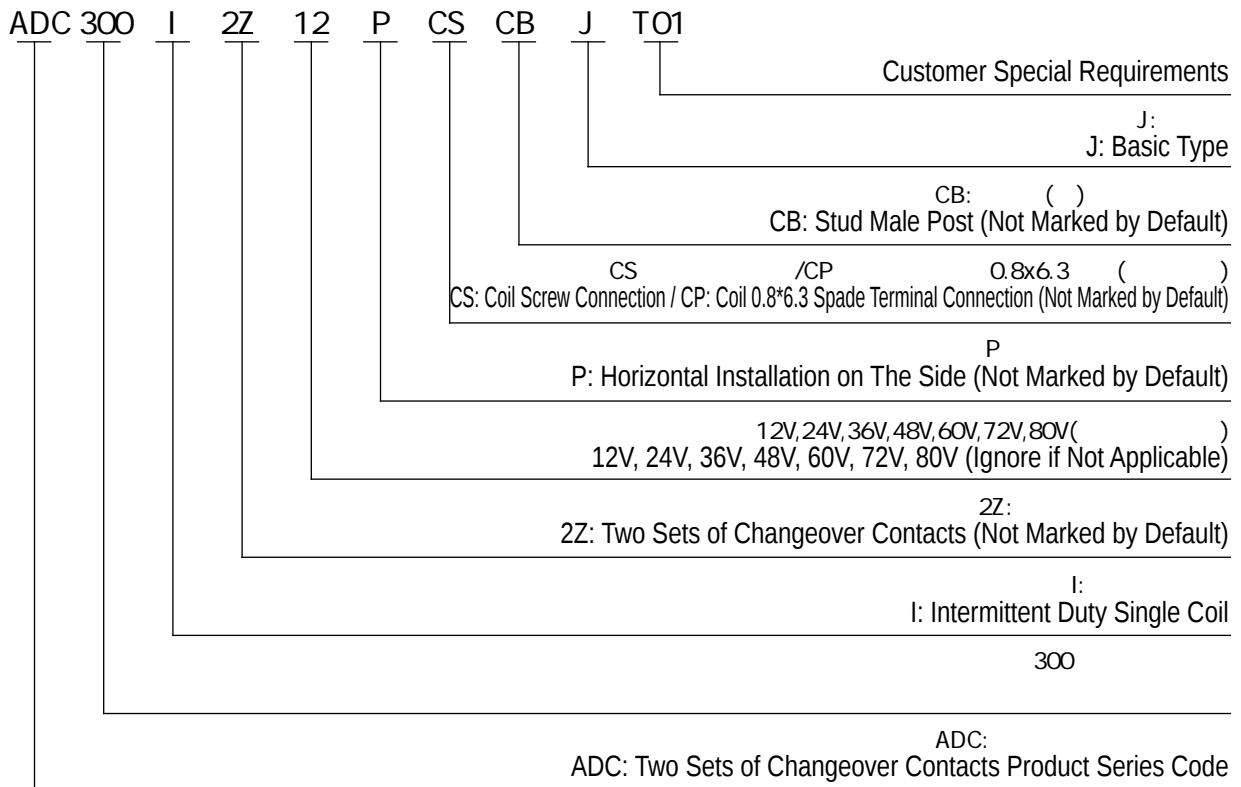

Wiring Diagram

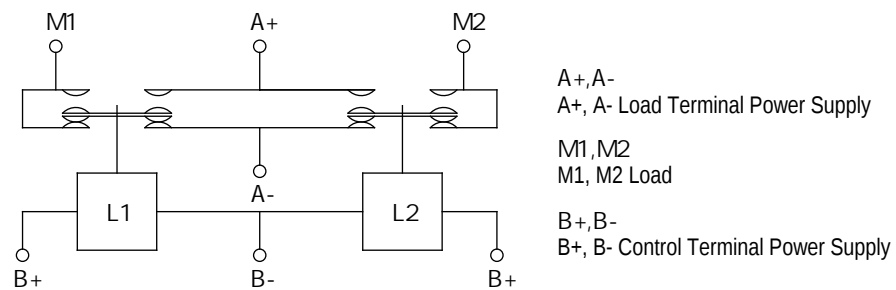

ADC300IJ
ADC300IJ Wiring Diagram

Outline Installation Dimension Drawing

ADC300ICSJ

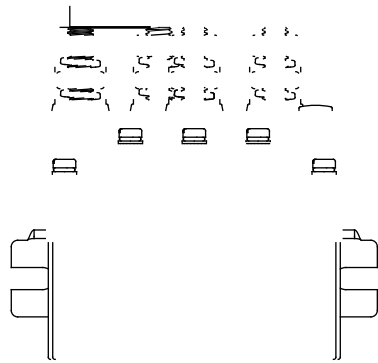

4-M6
Load Wiring 4-M6
3.0-6.0N.m
Torque 3.0-6.0N.m

3-M3
Coil Wiring 3-M3
0.5-0.8N.m
Torque 0.5-0.8N.m

ADC300IJ

4-M6
Load Wiring 4-M6
3.0-6.0N.m
Torque 3.0-6.0N.m

3-0.8x6.3
Coil Wiring 3-0.8*6.3

Outline Installation Dimension Drawing

ADC200IYCSJ

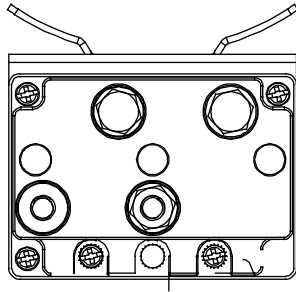

4-M6
Load Wiring 4-M6
3.0-6.0N.m
Torque 3.0-6.0N.m

3-M3
Coil Wiring 3-M3
0.5-0.8N.m
Torque 0.5-0.8N.m

ADC200IYJ

4-M6
Load Wiring 4-M6
3.0-6.0N.m
Torque 3.0-6.0N.m

3-0.8x6.3
Coil Wiring 3-0.8*6.3

1.